

Max diameter
2.160 mm
85"

Lift capacity
1.000 kg
2.200 lbs

Max diameter
2.400 mm
94"

Lift capacity
2.000 kg
4.400 lbs

Basic feature:
With
Extra
Length
And Tilt

Easy
Gripper
Crane
Module A

Save
time
Improve
safety



For mobile tyre service with truck cranes

- Unique 3-point grip
- Vertical tilt function
- Precise rotation +/-25°
- Easy hook on/off
- Possible customization for handling of rings etc.



Experts in Tyre Handling Equipment



Mobile service of OTR/EM and AGRO tyres

The Easy Gripper product range is designed to help tyre professionals in a multitude of conditions and situations. Implementing the Easy Gripper makes tyre handling faster and safer, while preventing damage to tyres, rims and equipment.

Installed on a truck crane, the Easy Gripper offers the optimal flexibility allowing the driver to be able to both transport and mount the big OTR or AGRO tyres and wheels – even single handedly.

With the Gripper very risky and time-consuming handling situations become safe and easy.



Safe 3-point grip

The unique 3-point grip offers optimal grip and control, when handling tyres and wheels. Together with the precise rotation and tilt functions hard and dangerous work can be avoided as well as damages on tyres, rims and equipment.

Quick shift & remote control

The Easy Gripper Crane Module can easily and quickly be mounted on the truck crane with a quick shift system. Further, the remote control system can easily be incorporated in the control system of the crane.



Solution for narrow space

Narrow space around tyres and fenders can quickly be solved. By loosening just one bolt the top arm can be exchanged with a flat arm, and the two bottom arms carry the tyre below the fender.

Light and compact

The Gripper has a light and compact design to optimize the center of gravity and the load capacity of the crane and of the total solution. The Crane Module provides the crane with an extra 160° tilt function.



Capability

With a gripping range of Ø2.400 mm (94") and a lifting capacity of 2 ton (4.400 lbs) at a CoG of 550 mm (22"), the Gripper can handle tyres up to 35". When you handle full wheel assemblies and as inside duals, the Gripper can handle up to 33" tyres depending of the kind of tyres and rims.

If you don't handle wheel assemblies bigger than 1 ton (2.200 lbs), you can choose a configuration with our Easy Gripper 2160, where we on request also can extend the gripping diameter to Ø2.400 mm (94") to handle even the biggest AGRO tyres.

Standard features

Handles both the Easy Gripper 2160 and 2400-2T

Unique and safe 3-point grip

Avoid accidents
Avoid deformation and damages of tyres
Avoid damages of rims and of the equipment

Precise rotation +/-25°

Tilt function 160°

Quick Shift System
Easy hook on and off.

Control system designed to be integrated with existing crane control system

Optional features

Integrated IR-camera system for optimal view

LED working light

Easy shift of gripping pipes for various purposes:

Flat top arm for narrow space
Telescopic pipes for long reach or 2 tyres handling

Tools for handling rings, to help tyre service technicians with the hard and dangerous work

Can easily be attached at the end of the gripping pipes
Can push the tyre and can hold and place the ring

Customization on request



Customization on request



Top safe



Telescopic arms



Optional integrated LED working light



Tools for handling rings and rims

Technical Data	Easy Gripper 2160	Easy Gripper 2400-2T
Gripping diameter:	1.200 - 2.160 mm (47 - 85")	1.450 - 2.400 mm (57 - 94")
- with special arms down to:	-	1.080 mm (43")
Standard arms:	Ø89 x 600 mm (Ø3.5 x 23.6")	Ø115 x 650 mm (Ø4.6 x 25.6")
Lifting capacity:	1.000 kg (2.200 lbs)	2.000 kg (4.400 lbs)
Weight:	830 kg (1.829 lbs)	1.035 kg (2.281 lbs)
Cg Total unit: A	1.250 mm (49.2")	1.450 mm (57")
Face of Gripper: B	1.530 mm (60.2")	1.660 mm (65.3")
Cg Load: C	2.030 mm (79.9")	2.210 mm (87")

Technical Requirements

Insert for mounting:	Crane specific	Crane specific
Lifting capacity:	Individual calculation	Individual calculation
Electrical:	12/24 V DC supply	12/24 V DC supply

Hydraulic

Flow max:	50 L/min (13.2 gal)	50 L/min (13.2 gal)
-----------	---------------------	---------------------

One, or preferable two, hydraulic proportional valves to control the Crane Module and the Gripper.

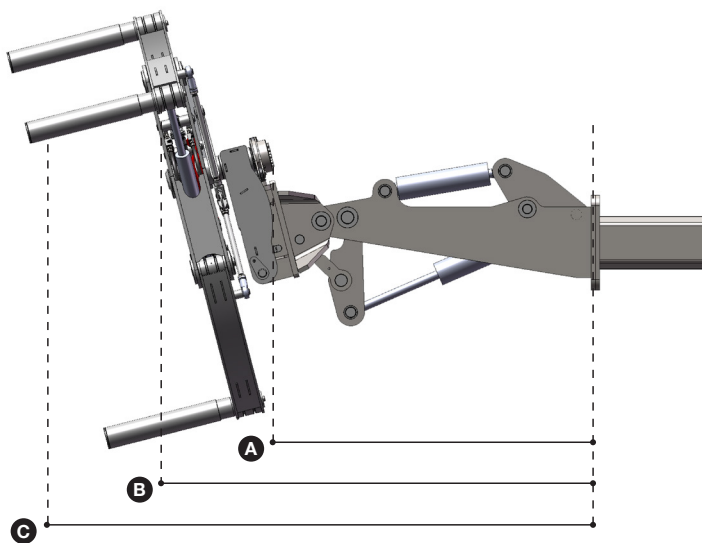

Authorized Dealer



+45 72 344 344
 info@justeasytools.dk
 www.justeasytools.dk
 VAT no.: DK33644809

Just Easy Tools ApS
 Nupark 51
 DK-7500 Holstebro
 Denmark