

Ideal for:  
Workshops  
Assembly Lines  
(with limited space)

Easy  
**Gripper**  
Workshop

Save  
**time**  
Improve  
safety



## Professional tyre handling tools for workshops and assembly lines

- Unique 3-point grip and turning radius
- Precise rotation +/-25°
- Easy and flexible to operate
- Very effective and safe – with integrated camera system
- Prevent damage to tyres & rims
- Customization available



Experts in Tyre Handling Equipment



# Easy Gripper Workshop

For safe and efficient tyre handling in workshops and at assembly lines with limited space. A perfect and flexible solution delivered "READY TO GO".

## Capability

Grips, lifts, moves and rotates tyres up to 2.160 mm (84") and 1.000 kg (2.200 lbs) at a CoG of 500 mm/20") On request the gripping diameter can be extended to 2.400 mm (94") to handle even the biggest AGRO tyres.



## Workshops

Solves issues with handling of big tyres and wheels, with lift, tilt, rotation and movements in areas with narrow space.

## Assembly lines

Grip a tyre/wheel and mount it on a vehicle. Very effective and safe compared to overhead cranes or other solutions – and with less internal damages of painting etc.



## Faster and more accurate

Manual handling and overhead cranes are often slow, potentially dangerous and inaccurate. If +/-15° tilt function is sufficient, the Easy Gripper Workshop is a perfect solution.

When moving – the visibility and camera ensure efficient logistics – and when installing, the slow mode and IR camera option gives the best condition for a fast, safe and accurate installation.

## Safer working environment

The Easy Gripper Workshop takes over most manual processes of lifting, moving and mounting large tyres – reducing strain and risks for the operator significantly.

The unique 3-point grip, with stone-coated arms, ensures that the Easy Gripper Workshop is in full control of the tyre during the whole process, until it is firmly mounted on a vehicle.





## Standard features

### Unique and safe 3-point grip

- Avoid accidents
- Avoid deformation and damages of tyres
- Avoid damages of rims and of the equipment

### Integrated IR-camera system for optimal view

### Precise rotation +/-25°

### Tilt function +/-15°

### Slow drive mode

- Controlled and accurate movements improve safety

### Turning radius 1.530 mm (60")

## Optional features

### Easy shift of gripping pipes for various purposes

- Flat top arm for narrow space

### LED working light

### Customization on request

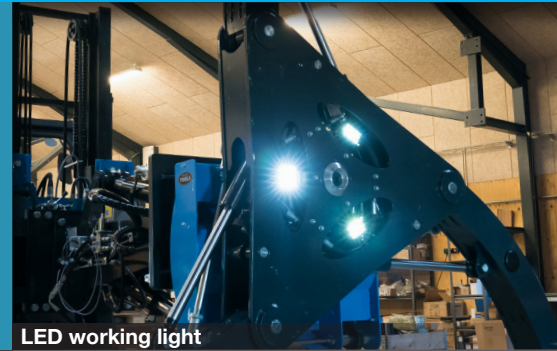

LED working light



Precise +/-15° tilt



Easy accessible controls



Stone-coated pipes ensure a safe grip

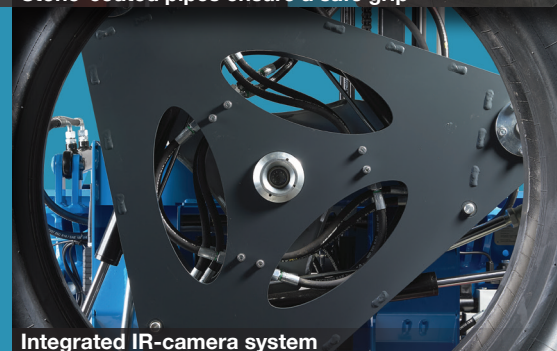

Integrated IR-camera system



Flat arm for narrow fenders

### Technical Specifications

Lifting capacity:	1.000 kg (2.200 lbs)
Tyre diameter:	1.200 - 2.160 mm (47-85")
Width of Stacker:	1.600 mm (63")
Min. turning radius:	1.530 mm (60")
Tilt from vertical position:	+/-15°
Rotation:	+/-25°

- A** Cg Machine = 385 mm (15,1")
- B** Rear of Load = 575 mm (22,6")
- C** Cg Load = 1.075 mm (42,3")
- D** Length = 1.175 mm (46,2")

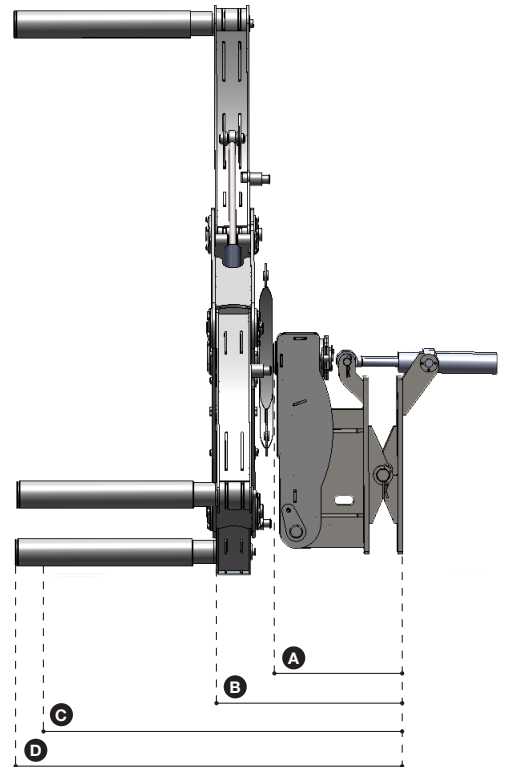

Authorized Dealer



+45 72 344 344  
info@justeasytools.dk  
www.justeasytools.dk  
VAT no.: DK33644809

Just Easy Tools ApS  
Nupark 51  
DK-7500 Holstebro  
Denmark